



Catalog Number 11030
UPC Number 60198611030
Description Non-Insulated Ring Terminals
22-16 AWG



Features

- Non-Insulated
- Manufactured from high strength copper alloy
- Electro-tin plated for corrosion resistance
- Brazed seam prevents splitting under maximum pressure
- Wire range stamped on the surface for easy interpretation

General

Insulation Type None
Material Copper
Finish Electro-tin plated
Color N/A
Wire Range 22-16
Stud Size 5/8

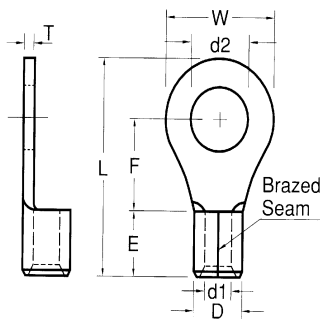

Dimension Information

L Inches (mm) 1.547
W Inches (mm) 1.063
D Inches (mm) 0.134
d1 Inches (mm) 0.067
d2 Inches (mm) 0.669
E Inches (mm) 0.189
F Inches (mm) 0.827
T Inches (mm) 0.031

Specifications

Temperature Rating 150°C
Voltage Rating 600 V
Flammability Rating N/A
Amp Rating
16 AWG 18 Amps
18 AWG 17 Amps
20 AWG 12 Amps
22 AWG 9 Amps

Packaging

Bag Qty 100
Master Bag Qty 1000

Certifications

UL Yes
cUL Yes
RoHS Yes

Morris Products 53 Carey Road, Queensbury, NY 12804

www.morrisproducts.com



REV	DESCRIPTION	DATE
△	RDK-96036	2007/08/09
△	RDK-97127	2008/10/17
△	RDK-98020	2009/09/30

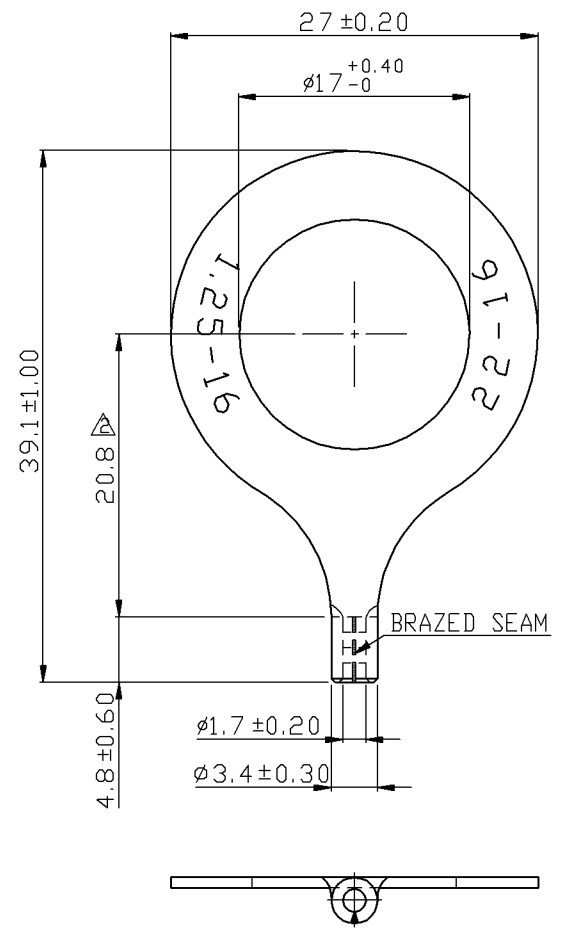

NOTE:

1. MAXIMUM ELECTRIC CURRENT :

A.W.G.	22	20	18	16
AMP.	9	12	17	18
2. WIRE RANGE : 22-16 A.W.G. ($0.5-1.5 \text{ mm}^2$)
3. SURFACE TREATMENT : TIN PLATED
4. THICKNESS : 0.80 mm

Tolerance Unless Otherwise Specified	
0 >	mm ± ANGLE
>	mm ± 0° ° REF ±
>	mm ± ° ° ±
>	mm ± ° ° ±

NAME	NON-INSULATED RING TERMINALS			UNIT	mm		
PART NO.	11030	MATERIAL	COPPER	APPROVE			
NUMBER		SCALE	SHEET	PAGE	CHECKED		
DATE	2006/09/27	2/1	1-3	10F2	DRAWN		

Morris Products Inc.