



Catalog Number 11036
UPC Number 60198611036
Description Non-Insulated Ring Terminals
 16-14 AWG



Features

- Non-Insulated
- Manufactured from high strength copper alloy
- Electro-tin plated for corrosion resistance
- Brazed seam prevents splitting under maximum pressure
- Wire range stamped on the surface for easy interpretation

General

Insulation Type None
Material Copper
Finish Electro-tin plated
Color N/A
Wire Range 16-14
Stud Size #6

Dimension Information

L Inches (mm) 0.567
W Inches (mm) 0.26
D Inches (mm) 0.161
d1 Inches (mm) 0.091
d2 Inches (mm) 0.146
E Inches (mm) 0.189
F Inches (mm) 0.248
T Inches (mm) 0.031

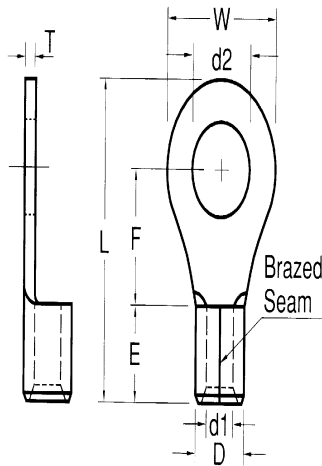

Specifications

Temperature Rating 150°C
Voltage Rating 600 V
Flammability Rating N/A
Amp Rating 16 AWG 18 Amps
 14 AWG 30 Amps

Packaging

Bag Qty 100
Master Bag Qty 1000

Certifications

UL Yes
cUL Yes
RoHS Yes

Morris Products 53 Carey Road, Queensbury, NY 12804

www.morrisproducts.com



REV	DESCRIPTION	DATE
△	RDK-96036	2007/09/12
△	RDK-97127	2008/10/20
△	RDK-98020	2009/09/30

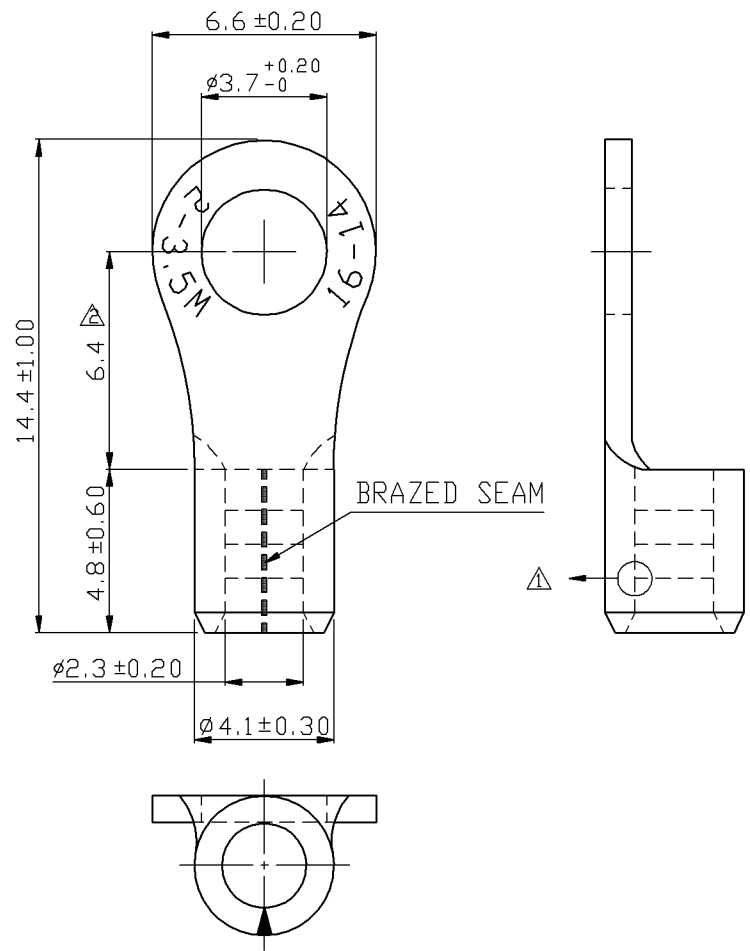

- NOTE :
1. MAXIMUM ELECTRIC CURRENT :

A.W.G.	16	14	
AMP.	18	30	
 2. WIRE RANGE : 16-14 A.W.G. (1.5-2.5 mm²)
 3. SURFACE TREATMENT : TIN PLATED
 4. THICKNESS : 0.80 mm

△ Tolerance Unless Otherwise Specified	
> mm ±	ANGLE
> mm ±	0° ° REF ±
> mm ±	° ° ±
> mm ±	° ° ±

NAME	NON-INSULATED RING TERMINALS			UNIT	mm	
PART NO.	11036	MATERIAL	COPPER	APPROVE		
NUMBER		SCALE	SHEET	PAGE	CHECKED	
DATE	2006/09/26	5/1	1-3	10F2	DRAWN	

Morris Products Inc.