



Catalog Number 11062
UPC Number 60198611062
Description Non-Insulated Ring Terminals
12-10 AWG



Features

- Non-Insulated
- Manufactured from high strength copper alloy
- Electro-tin plated for corrosion resistance
- Brazed seam prevents splitting under maximum pressure
- Wire range stamped on the surface for easy interpretation

General

Insulation Type None
Material Copper
Finish Electro-tin plated
Color N/A
Wire Range 12-10
Stud Size 1/4

Dimension Information

L Inches (mm) 0.886
W Inches (mm) 0.472
D Inches (mm) 0.22
d1 Inches (mm) 0.134
d2 Inches (mm) 0.252
E Inches (mm) 0.236
F Inches (mm) 0.472
T Inches (mm) 0.039

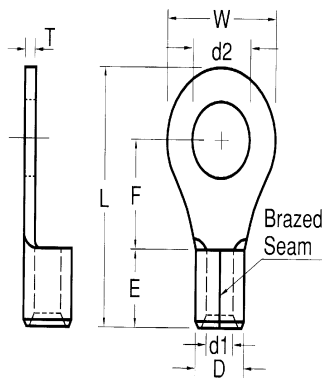

Specifications

Temperature Rating 150°C
Voltage Rating 600 V
Flammability Rating N/A
Amp Rating 12 AWG 35 Amps
10 AWG 50 Amps

Packaging

Bag Qty 100
Master Bag Qty 1000

Certifications

UL Yes
cUL Yes
RoHS Yes

Morris Products 53 Carey Road, Queensbury, NY 12804

www.morrisproducts.com

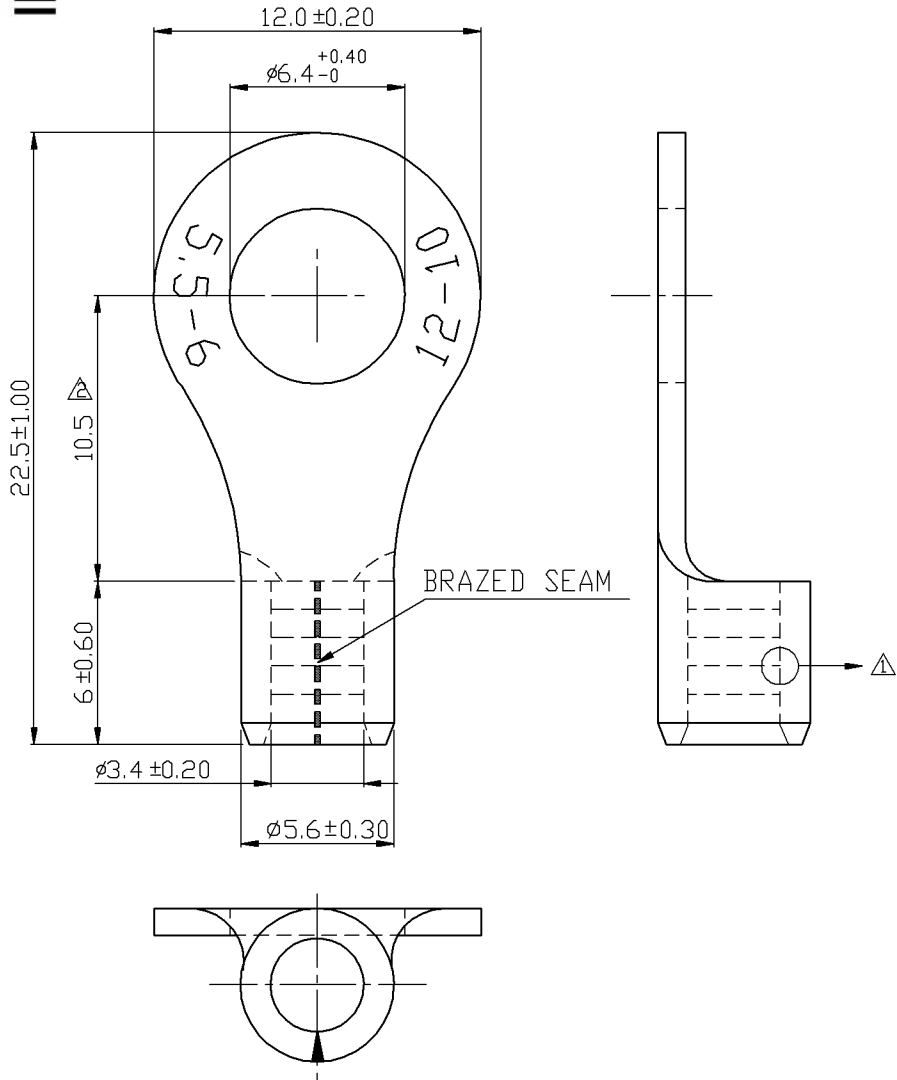

REV	DESCRIPTION	DATE
△ RDK-96036		2007/10/18
△ RDK-97127		2008/10/15
△ RDK-98020		2009/09/22

- NOTE :
- MAXIMUM ELECTRIC CURRENT :

A.W.G.	12	10	
AMP.	35	50	
 - WIRE RANGE : 12-10 A.W.G. (4 - 6 mm²)
 - SURFACE TREATMENT : TIN PLATED
 - THICKNESS : 1.00 mm

△ Tolerance Unless Otherwise Specified	
> mm ±	ANGLE
> mm ±	0° REF ±
> mm ±	° ±
> mm ±	° ±

NAME	NON-INSULATED RING TERMINALS			UNIT	mm	
PART NO.	11062	MATERIAL	COPPER	APPROVE		
NUMBER		SCALE	SHEET	PAGE	CHECKED	
DATE	2006/09/26	4/1	1-3	10F2	DRAWN	

Morris Products Inc.