



Catalog Number 11924
UPC Number 60198611924
Description Nylon Insulated Female Disconnect Connectors
16-14 AWG



Features

- Nylon Color Coded insulation for easy identification
- Manufactured from high strength copper alloy
- Electro-tin plated for corrosion resistance
- Expanded insulation eliminates strand “Hang Up”, provides strain relief & excellent UV, temperature and chemical resistance
- Wire range stamped on the surface for easy interpretation
- Brazed seams prevent splitting under maximum pressure
- Serrated barrel provides excellent electrical contact & pull-out force resistance

General

Insulation Type Nylon
Material Brass
Finish Electro-Tin Plated
Color Blue
Wire Range 16-14
Tab Size .032 X .250

Dimension Information

Stock Thickness 0.016
L Inches (mm) 0.846
B Inches (mm) 0.433
C Inches (mm) 0.091
D Inches (mm) 0.197
F Inches (mm) 0.287
W Inches (mm) 0.26

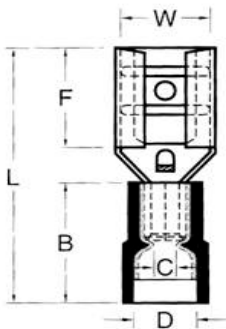

Specifications

Temperature Rating 105°C
Voltage Rating 300 V
Flammability Rating UL94V-O
Amp Rating 14 AWG 30 Amps
16 AWG 18 Amps

Packaging

Bag Qty 100
Master Bag Qty 1000

Certifications

UL Yes
cUL Yes
RoHS Yes

Morris Products 53 Carey Road, Queensbury, NY 12804

www.morrisproducts.com



REV	DESCRIPTION	DATE
-----	-------------	------

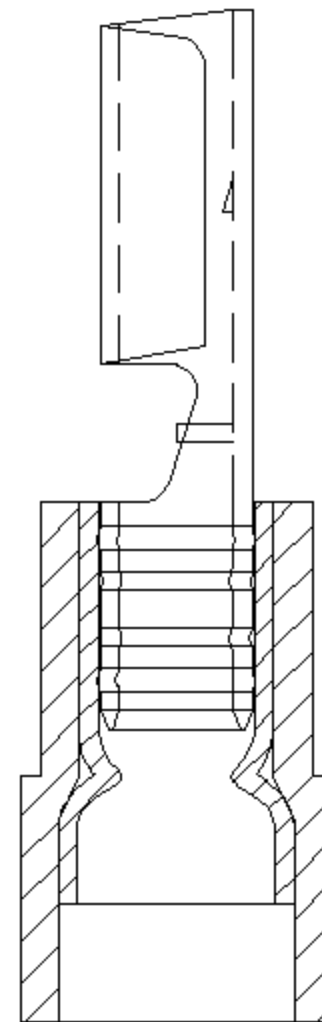
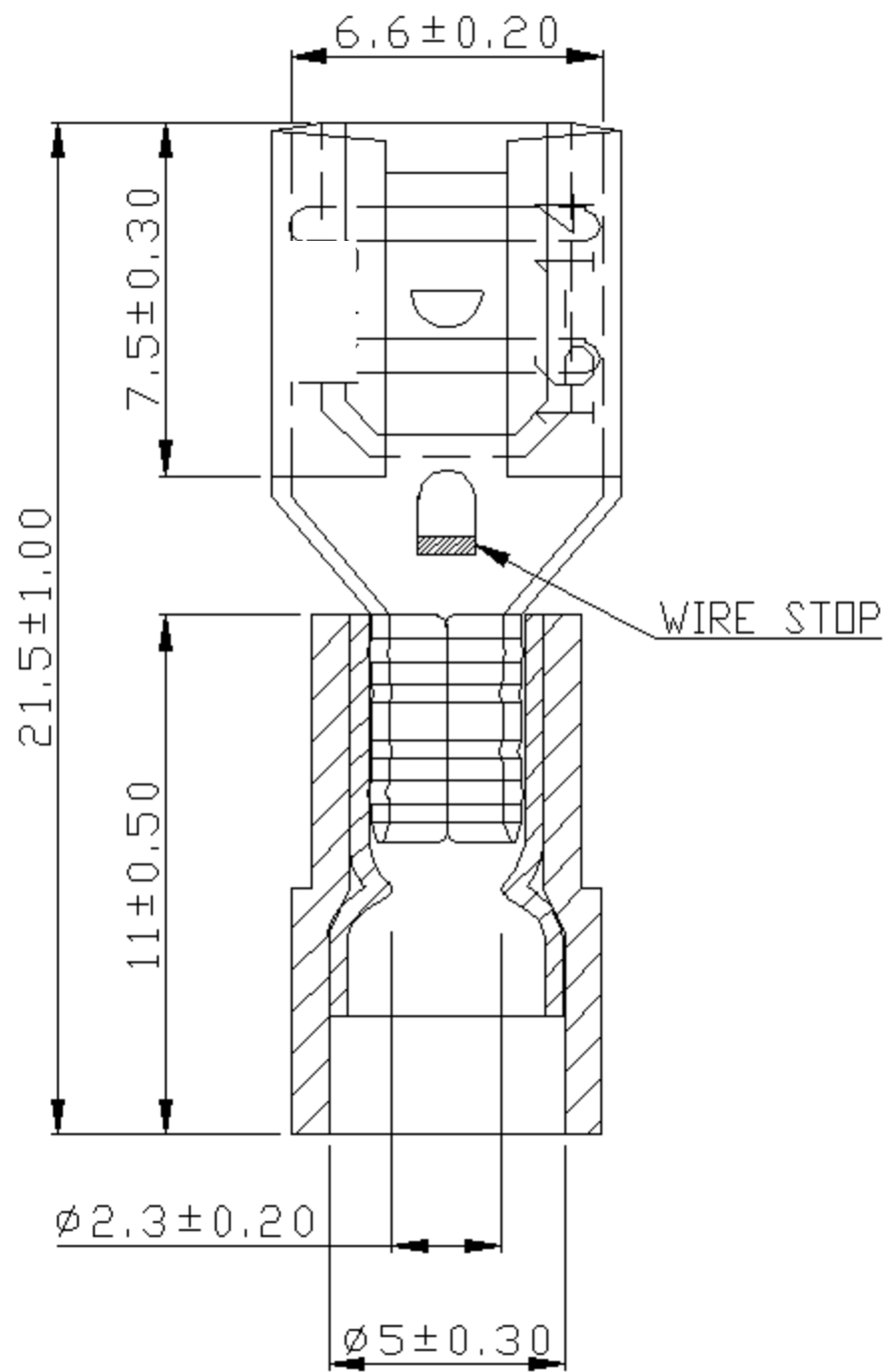
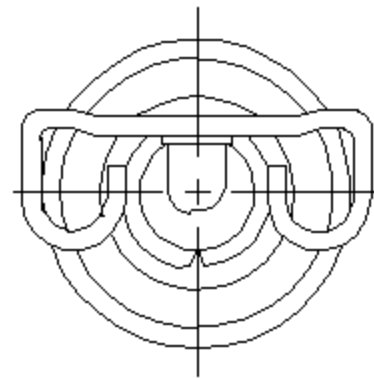

NOTE:

1. MAXIMUM ELECTRIC CURRENT :

A.W.G.	16	14	
AMP.	10	15	
2. MAXIMUM ELECTRICAL RATING : 105°C 600 VOLTS MAX.
3. INSULATION MATERIAL : NYLON
4. INSULATION COLOR : BLUE
5. TERMINAL MATERIAL : BRASS
6. WIRE RANGE : 16-14 A.W.G.(1.5-2.5 mm²)
7. TERMINALS SURFACE TREATMENT : TIN PLATED
8. DOUBLE CRIMP : WITH COPPER SLEEVE ON BARREL
9. NEMA TAB : 0.032 * 0.250 (0.8 * 6.35)
10. TERMINALS THICKNESS : 0.40 mm

Tolerance Unless Otherwise Specified			
0 > 6 mm	±0.20	ANGLE	
6 > 18 mm	±0.30	0°	° REF ±
18 > 30 mm	±0.40	°	° ±
30 > 75 mm	±0.50	°	° ±

NAME	NYLON-INSULATED DOUBLE CRIMP FEMALE DISCONNECTORS			UNIT	mm	
PART NO.	11924	MATERIAL	-----	APPROVE		
NUMBER		SCALE	SHEET	PAGE	CHECKED	
DATE	2006/08/14	4/1	1-0	10F2	DRAWN	

Morris Products Inc.