



Catalog Number 11944
UPC Number 60198611944
Description Nylon Insulated Male Disconnect Connectors
 22-16 AWG



Features

- Nylon Color Coded insulation for easy identification
- Manufactured from high strength copper alloy
- Electro-tin plated for corrosion resistance
- Expanded insulation eliminates strand “Hang Up”, provides strain relief & excellent UV, temperature and chemical resistance
- Wire range stamped on the surface for easy interpretation
- Brazed seams prevent splitting under maximum pressure
- Serrated barrel provides excellent electrical contact & pull-out force resistance

General

Insulation Type Nylon
Material Brass
Finish Electro-Tin Plated
Color Red
Wire Range 22-16
Tab Size .032 X .110

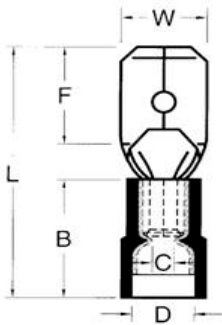

Dimension Information

Stock Thickness 0.016
L Inches (mm) 0.756
B Inches (mm) 0.413
C Inches (mm) 0.067
D Inches (mm) 0.15
F Inches (mm) 0.256
W Inches (mm) 0.11

Specifications

Temperature Rating 105°C
Voltage Rating 300 V
Flammability Rating UL94V-O
Amp Rating

22 AWG	9 Amps
20 AWG	12 Amps
18 AWG	17 Amps
16 AWG	18 Amps

Packaging

Bag Qty 100
Master Bag Qty 1000

Certifications

UL Yes
cUL Yes
RoHS Yes



REV	DESCRIPTION	DATE
-----	-------------	------

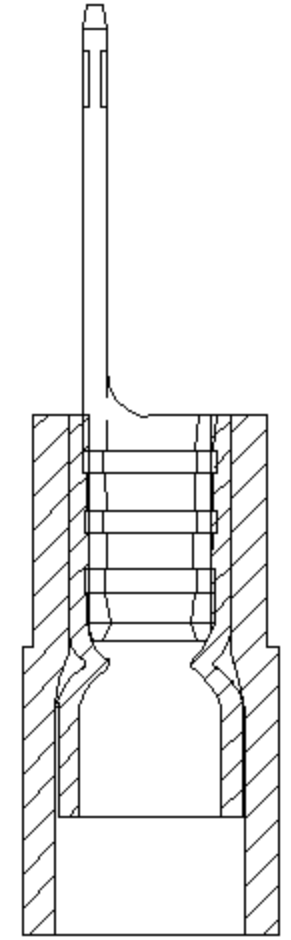
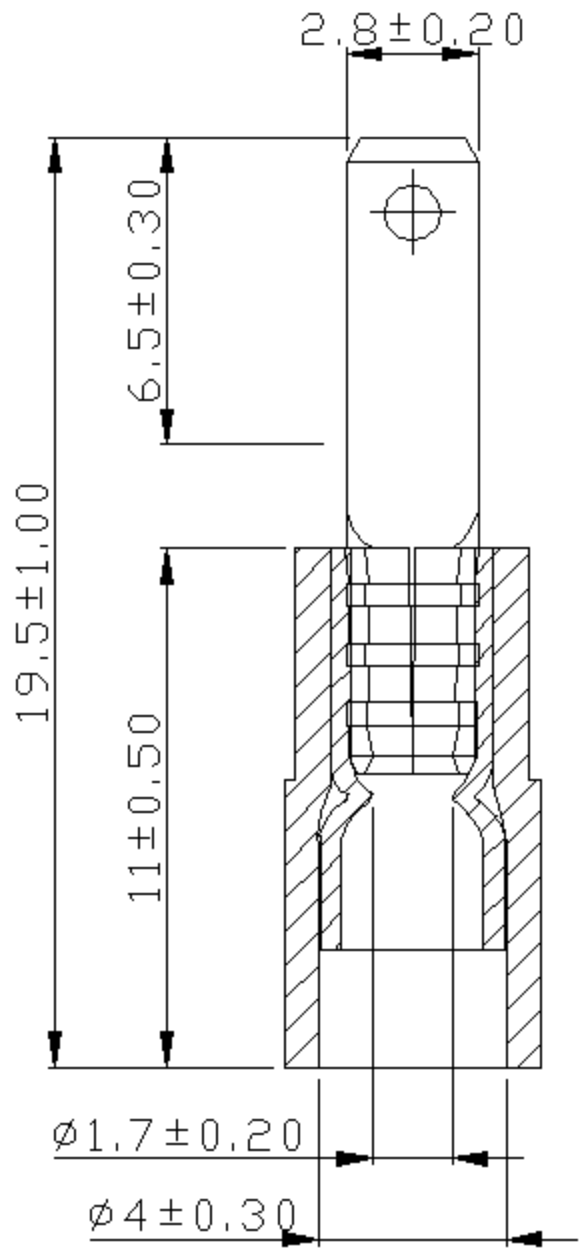

- NOTE:
1. MAXIMUM ELECTRIC CURRENT :

A.W.G.	22	20	18	16
AMP.	3	4	7	10
 2. MAXIMUM ELECTRICAL RATING : 105°C 600 VOLTS MAX.
 3. INSULATION MATERIAL : NYLON
 4. INSULATION COLOR : RED
 5. TERMINAL MATERIAL : BRASS
 6. WIRE RANGE : 22-16 A.W.G.(0.5-1.5 mm²)
 7. TERMINALS SURFACE TREATMENT : TIN PLATED
 8. DOUBLE CRIMP : WITH COPPER SLEEVE ON BARREL
 9. NEMA TAB : 0.032 * 0.110 (0.8 * 2.8)
 10. TERMINALS THICKNESS : 0.4 mm

Tolerance Unless Otherwise Specified	
0 >6 mm ±0.20	ANGLE
6 >18 mm ±0.30	0° REF ±
18 >30 mm ±0.40	±
30 >75 mm ±0.50	±

NAME	NYLON-INSULATED DOUBLE CRIMP MALE DISCONNECTORS				UNIT	
PART NO.	11944	MATERIAL	-----	APPROVE		
NUMBER		SCALE	SHEET	PAGE	CHECKED	
DATE	2006/08/28	4/1	1-0	10F2	DRAWN	

Morris Products Inc.