



**Catalog Number** 12318  
**UPC Number** 60198612318  
**Description** Heat Shrinkable Bullet Disconnect  
12-10 AWG  
.197 OD



#### Features

Color Coded HD Polyethylene Heat Shrink insulation  
Manufactured from high strength copper alloy  
Electro-tin plated for corrosion resistance  
Expanded Insulation funnel entry eliminates strand “Hang Up”, increases the crimping rates and the reliability of the termination  
Wire range stamped on the surface for easy interpretation  
Brazed seam prevent splitting under maximum pressure  
Serrated barrel & extended copper crimp sleeve provide excellent electrical contact, pull-out resistance & mechanical stress relief

#### General

Insulation Type High Density Polyethylene Heat Shrink  
Material Copper  
Finish Electro-tin plated  
Color Yellow  
Wire Range 12-10 AWG  
Bullet OD .197

#### Dimension Information

L Inches (mm) 1.398  
W Inches (mm) 0.197  
D Inches (mm) 0.319

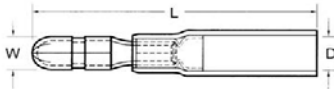

#### Specifications

Temperature Rating 105°C  
Voltage Rating 300 V  
Flammability Rating UL94V-O  
Amp Rating 12 AWG 20 Amps  
10 AWG 24 Amps

#### Packaging

Bag Qty 100  
Master Bag Qty 1000

#### Certifications

UL Yes  
cUL Yes  
RoHS Yes

Morris Products 53 Carey Road, Queensbury, NY 12804

[www.morrisproducts.com](http://www.morrisproducts.com)



REV	DESCRIPTION	DATE
△ RDK-97140		2008/07/11

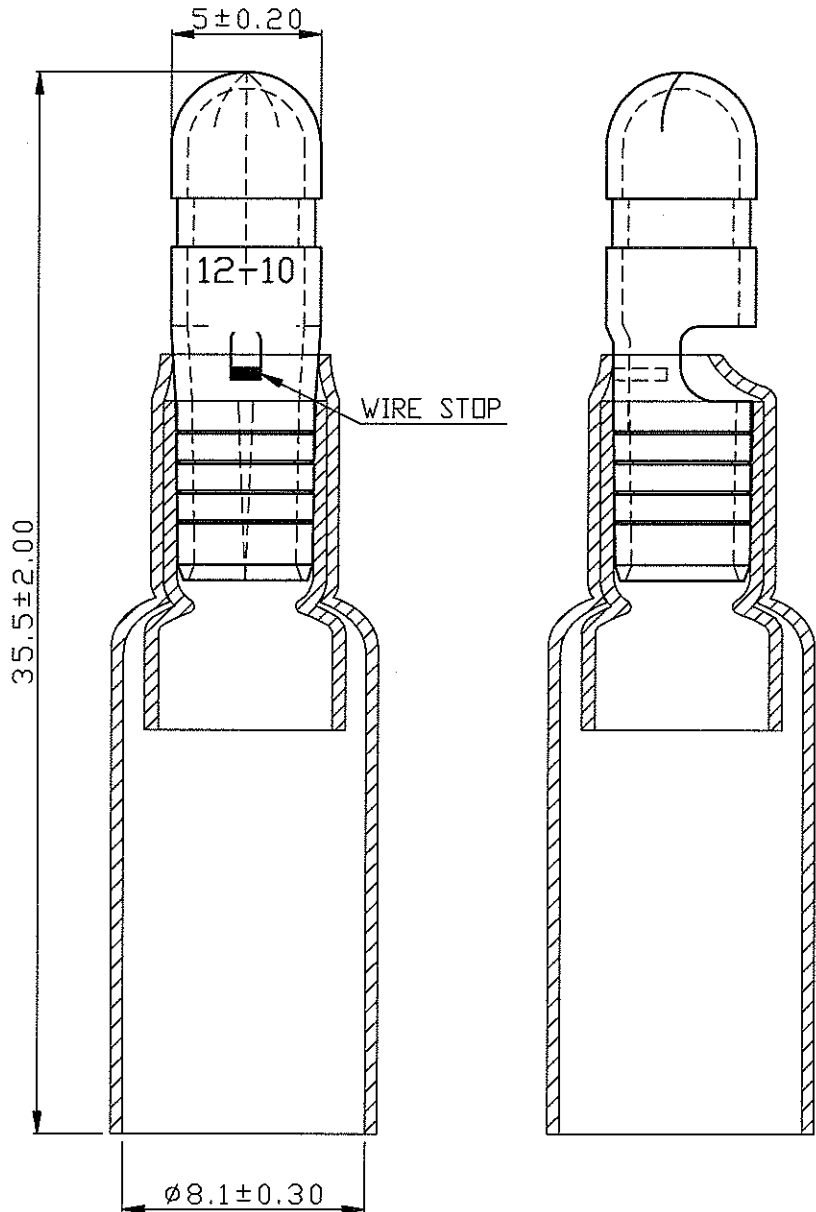

NOTE :

- MAXIMUM ELECTRIC CURRENT : 

A.W.G.	12	10	
AMP.	20	24	
- MAXIMUM ELECTRICAL RATING : 300 VOLTS MAX.
- SHRINK TEMP. :  $150^{\circ}\text{C}$  △
- OPERATING TEMP. :  $-40^{\circ}\text{C} \sim +105^{\circ}\text{C}$
- INSULATION MATERIAL : HIGH DENSITY PE.
- INSULATION MATERIAL : WITH COPPER SLEEVE ON BARREL
- INSULATEDN COLOR : YELLOW
- WIRE RANGE : 12-10 A.W.G. (  $4 - 6 \text{ mm}^2$  )
- TERMINAL MATERIAL : BRASS
- TERMINAL SURFACE TREATMENT : TIN PLATED
- TERMINAL THICKNESS : 0.40 mm

Tolerance Unless Otherwise Specified	
0 > 6 mm ± 0.20	ANGLE
6 > 18 mm ± 0.30	0° ° REF ±
18 > 30 mm ± 0.40	° ±
30 > 75 mm ± 0.50	> ° ±

NAME	HEAT SHRINKABLE-BULLET DISCONNECTORS (HD DOUBLE CRIMP TYPE)			UNIT	
PART NO.	12318	MATERIAL	-----	APPROVE	
NUMBER		SCALE	SHEET	PAGE	CHECKED
DATE	2005/12/27	4/1	1-1	10F2	DRAWN

Morris Products Inc.